



# SAFETY & OPERATIONS MANUAL

**DO NOT throw away these instructions!**  
**Read and understand these instructions before using this product.**

## Table of Contents

**PX3 Mobile Fall Protection Cart**     **Part ID: 72810**

### Foundational Knowledge & Safety Compliance

Introduction	2
Applications	3
Safety Precautions	4
Safety & Warning Labels	5
Declaration of Conformity (DOC)	8
Hoisting Safety & Precautions	10
Roof Loading Requirements	11
Rescue Plan & Rescue Winch Installation	12

### Operational Guidance for Jobsite Use

Recommended Surfaces	16
Placement/Positioning of Cart	16
Range of Use	17
Connection Points	18
Parts List Overview	19
Safety Checklist	20
	(Back Cover)

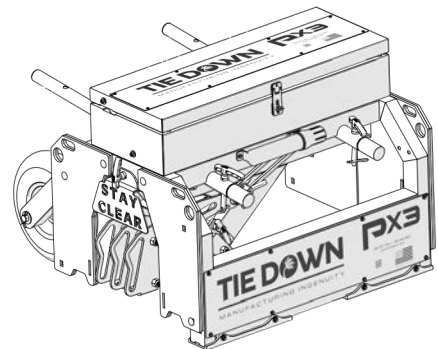

Online Manual  
(English)

Use these instructions as part of a training program as required by OSHA and any applicable state agency. The user must understand how to safely use the Penetrator and all safety equipment used in combination with the Penetrator Fall Protection device.

A competent person who is highly trained and experienced, assigned by the employer, must be responsible for all elements of a fall safety program, including the regulation, management, and application as it relates to the use of the Penetrator and related components.



WARNING: This product can expose you to chemicals including Nickel, which is known to the State of California to cause cancer.  
 For more information go to: [www.P65Warnings.ca.gov](http://www.P65Warnings.ca.gov)

Instruction Sheet #08383  
 E1847, Rev. 5/10/24



4404-344-0000 • [www.tiedown.com](http://www.tiedown.com)  
 605 Stonehill Drive SW, Atlanta, GA 30336  
[sales@tiedown.com](mailto:sales@tiedown.com)

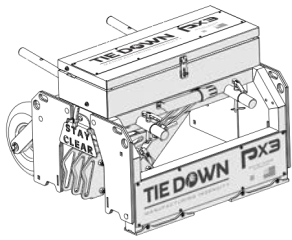

Part ID:  
72810

# PX3

**MOBILE FALL PROTECTION**

## ⚠️ WARNING ⚠️

Serious injury or death may occur if this equipment is used for purposes other than intended. Tie Down Engineering provides the following instructions for the use and care of this equipment. It is the responsibility of the user to understand and convey proper instruction to any and all individuals who use this product for Fall Arrest and or Fall Restraint.

The PX3 complies with the requirements set forth by the Federal Occupational Safety and Health Administration (OSHA) when used according to the manufacturers' instructions.

## Key Features

The PX3 Penetrating Mobile Fall Protection Unit offers a range of key features designed for safety and efficiency on various roofing materials. This section details the unit's specifications, safety compliance, and capacity to support up to five workers.

### USERS: TOTAL 5 WORKERS



3

FALL  
ARREST



2

FALL  
RESTRAINT



### Key Features

- For use on TPO, EPDM, metal and built-up roofing
- Unit Weight: 430 Lbs
- Standard locking toolbox
- Instruction Manual Holder & on-product QR Code
- Retractable handles
- Five steel spikes for roof penetration
- Optional rescue winch with 100 ft. of galvanized lifeline
- flat-free 300 lb. tires

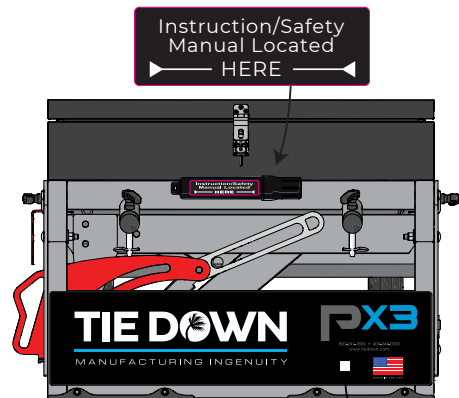

**COMPLIANCE: OSHA 1910.140 & 1926.502**

**\*\*\*SEE DOC PAGES 8-9\*\*\***

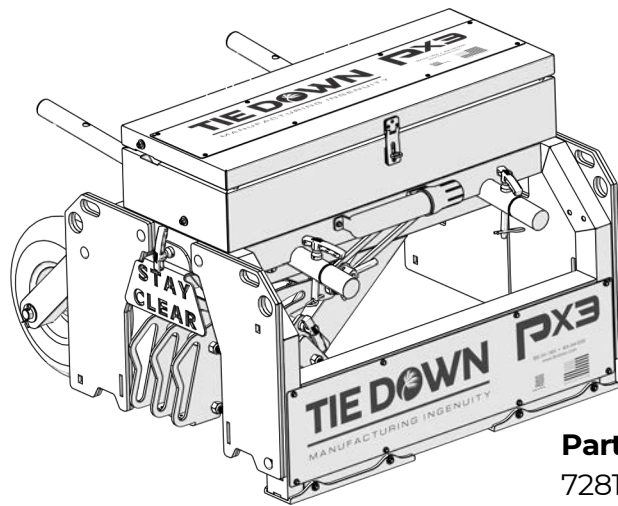

Part ID:  
72810



## Applications

When set up properly the PX3 allows for three workers to be tied off for fall arrest using the specially designed fall arrest connection mechanism. An additional two workers can be tied-off for fall restraint at the specified attachment points.

**Fall restraint** is a proactive measure designed to prevent falls from occurring in the first place. It involves implementing preventive measures through components such as body harnesses attached to anchorage, connectors, and other necessary equipment. The primary objective is to restrict a worker's movement and prevent them from reaching a position where a fall hazard exists. **The PX3 can be used as an anchorage in a fall restraint system for up to two workers.**

**Fall Arrest** can be used when fall restraint is not ideal or not an option. It involves utilizing equipment and systems that can effectively arrest the fall and minimize the potential injury or damage. Fall arrest systems typically consist of anchors, anchorage points, connectors, and personal protective equipment (PPE) such as harnesses and lanyards. These components work together to ensure the worker's safety by stopping their fall and preventing them from striking lower levels or encountering other hazards. **The PX3 can be used as an anchorage in a personal Fall Arrest System (PFAS) for up to three workers.**

A fall arrest system must meet the following OSHA requirements:

- 1910.140(d)(1)(i) Limit the maximum arresting force on the employee to 1,800 pounds (8 kN)
- 1910.140(d)(1)(ii) Bring the employee to a complete stop and limit the maximum deceleration distance the employee travels to 3.5 feet (1.1 m);
- 1910.140(d)(1)(iii) Have sufficient strength to withstand twice the potential impact energy of the employee free falling a distance of 6 feet (1.8 m), or the free fall distance permitted by the system

**Anchorage** — Anchorage means a secure point of attachment for equipment such as lifelines, lanyards, or deceleration devices. PX3 is an engineered mobile anchorage device.

**PX3 Use** - Flat surfaces to slopes up to 1:12.

## Before Using the PX3

OSHA requires that before operating the system there must be an inspection for damaged equipment.

1. Check for loose, bent or damaged parts, including the five penetrating spikes.
2. Check welded components for distortion, cracks, or other damage.
3. Check Tie-off shackles for distortion or damage and confirm that they are properly tightened.
4. Check retaining slide bars for rusting and/or wear before each use. All labels must be present and fully legible. (Copies of all labels are attached at the back of this section for accurate inspection.)
5. Check for all pull pins that they are fully inserted and the safety cotter pin clips are attached to each pull pin.

## Maintenance and Care

- Inspect PX3 before and after each use.
- Keep wheels free from roofing debris
- Regularly inspect for damaged or missing parts and do not place the PX3 into service until all missing and or damaged parts have been replaced.
- Store the PX3 in a place protected from weather and where only authorized employees have access.
- Maintain finish to prevent corrosion.

## General Safety Precautions

- **EXERCISE GOOD JUDGEMENT!** Most accidents can be avoided by using common sense and concentrating on the job at hand. Look around and confirm a safe distance from the roof edge is being maintained.
- The PX3 should not be used by persons whose ability or alertness is impaired by fatigue, intoxicating beverages, illegal or prescription drugs, or any other physical cause that exposes the user or others to injury.
- Always wear proper safety attire.
- Keep hands and feet clear of moving parts. DO NOT stick hands or fingers in the equipment when workers are attached to the PX3.
- Do not operate the equipment near electrical power lines. **ELECTRICITY KILLS!**
- Ensure that all areas directly underneath, and in front of the cart, are clear and free of debris.
- Do not use on roofs with ice or snow.
- Only use the unit on a surface or roof composition for which it has been tested.
- Do not set unit atop unfastened materials. Materials may slide if not mechanically attached to the roof.

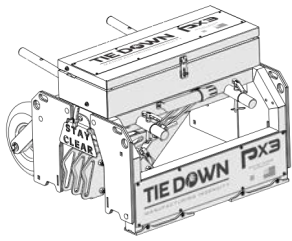

Part ID:  
72810

# PX3

MOBILE FALL PROTECTION

## Safety & Warning Labels

The PX3 Penetrating Mobile Fall Protection Unit is equipped with clear, on-product warning and safety labels. These labels identify the correct connection points for fall arrest, fall restraint, and hoisting, as well as provide warning for any safety concerns. By highlighting these critical points, the unit enhances safety compliance and ensures proper use, helping to protect users on the job site.

**CHECK ALL LABELS TO ENSURE PROPER CONNECTION PRIOR TO USE.**

## PX3

Label Placement 5/9/24

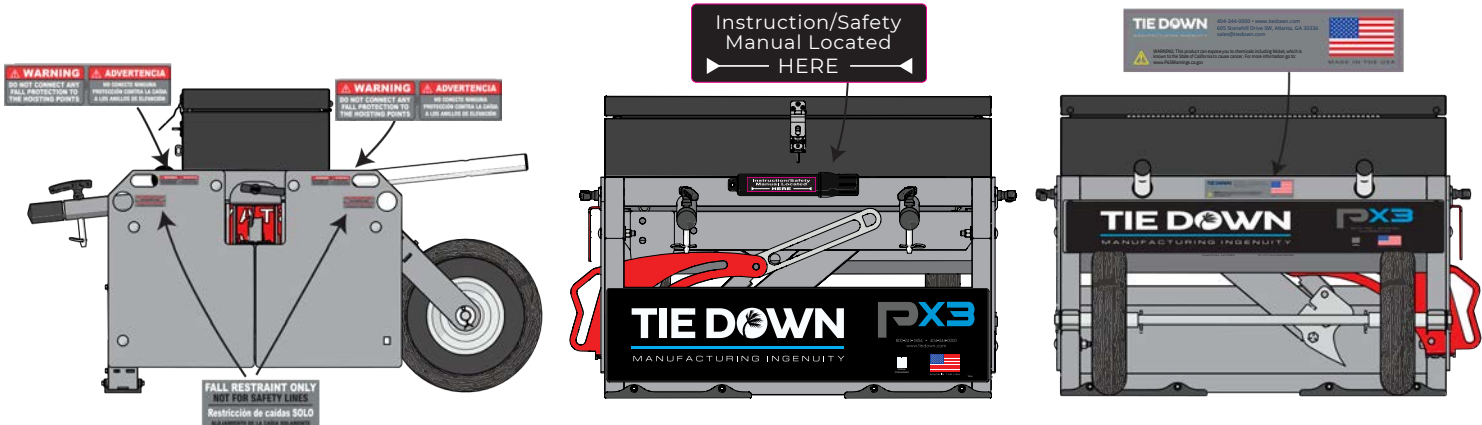
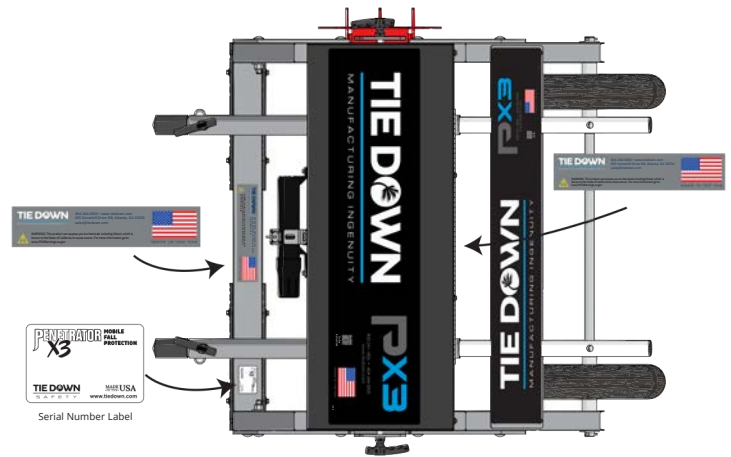
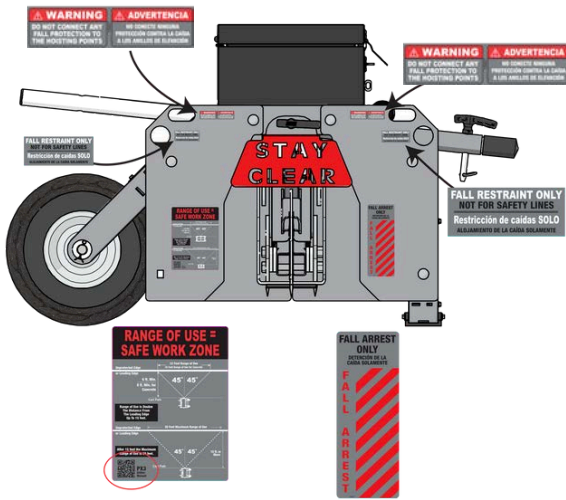

# On-Product Safety Labels

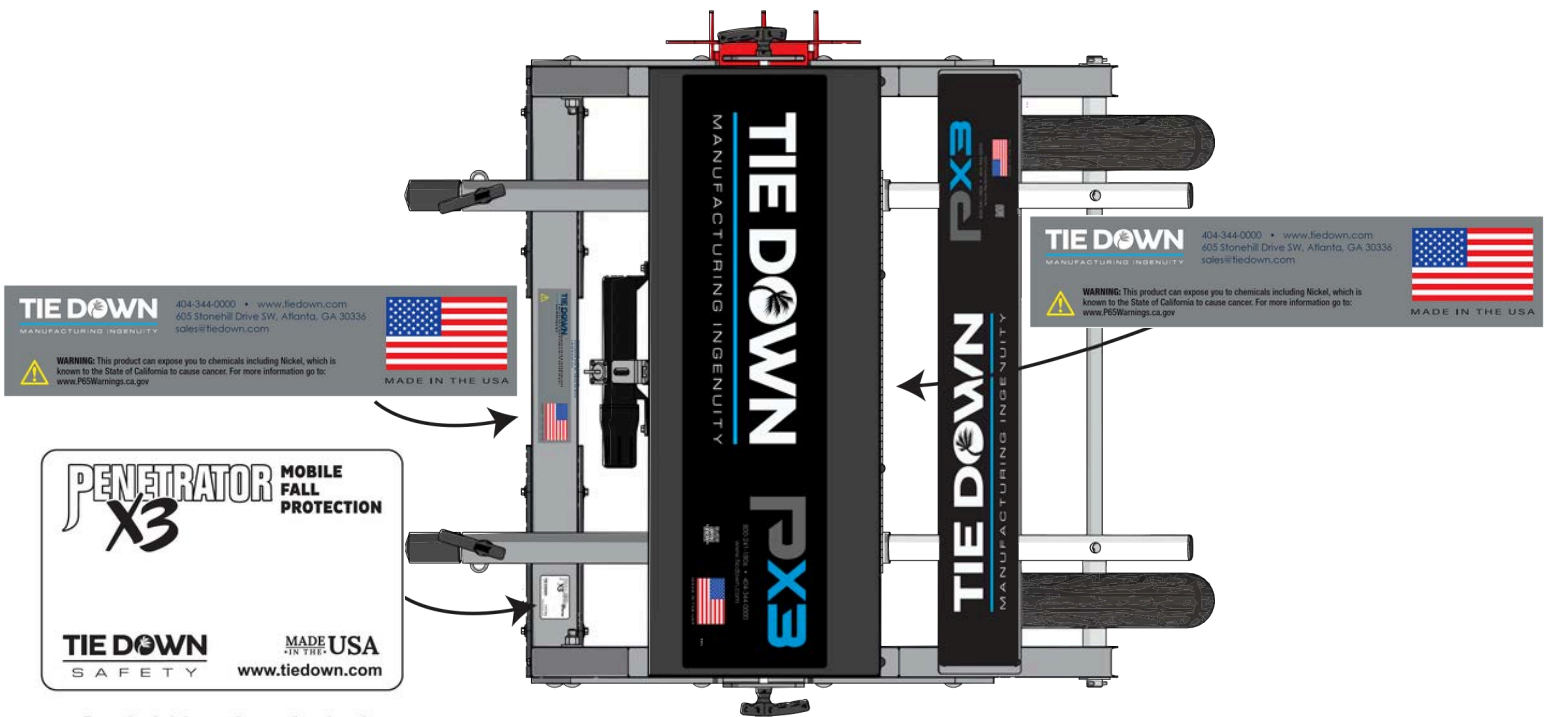
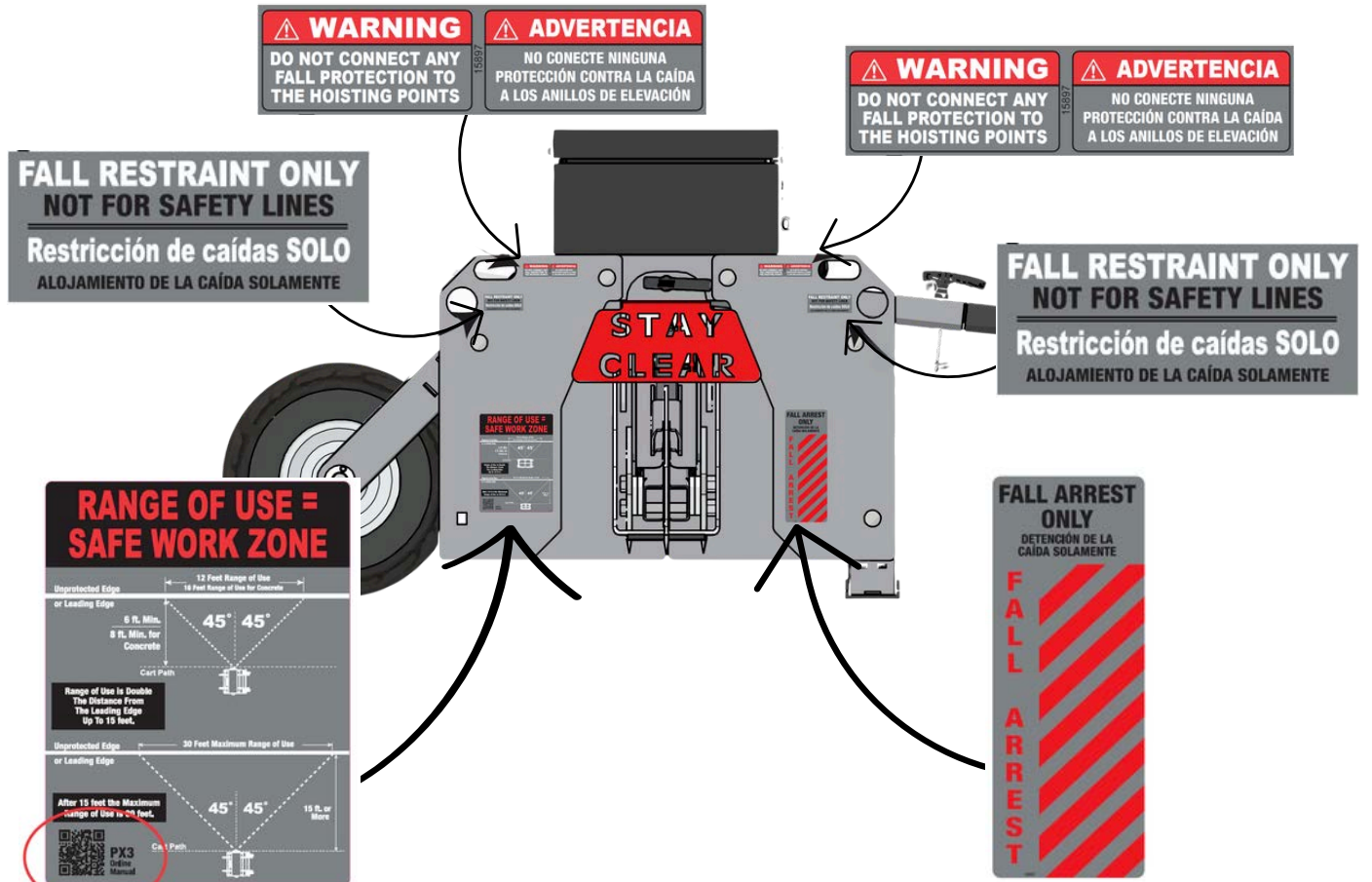

Serial Number Label

# On-Product Safety Labels

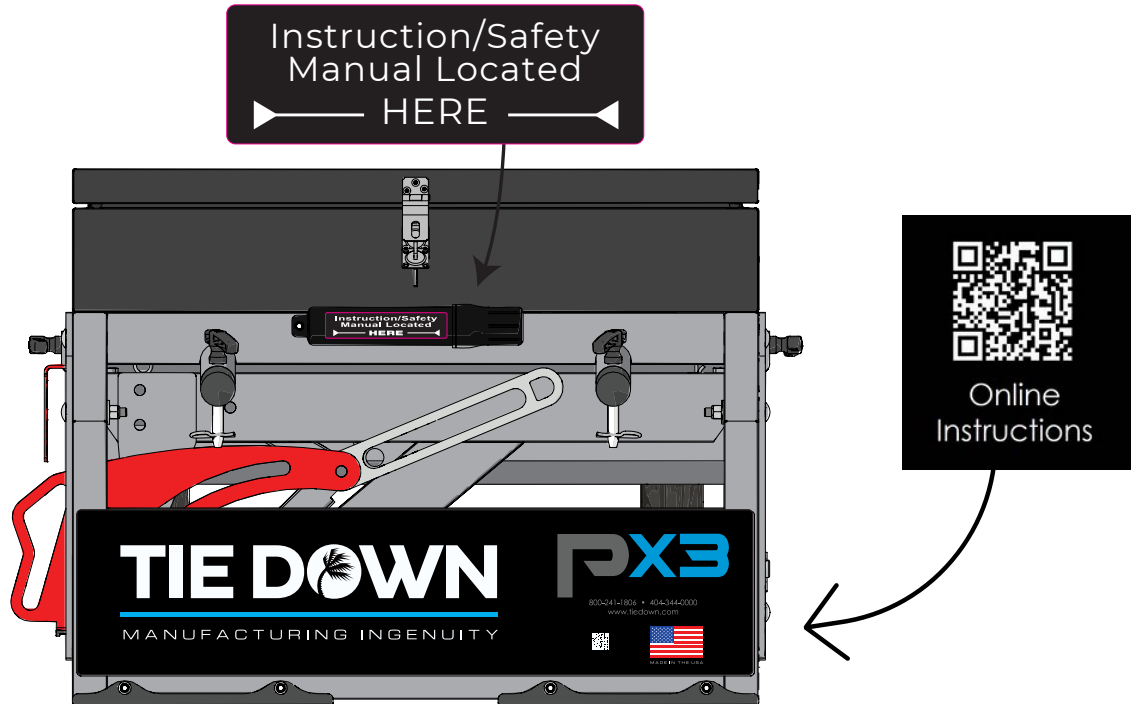
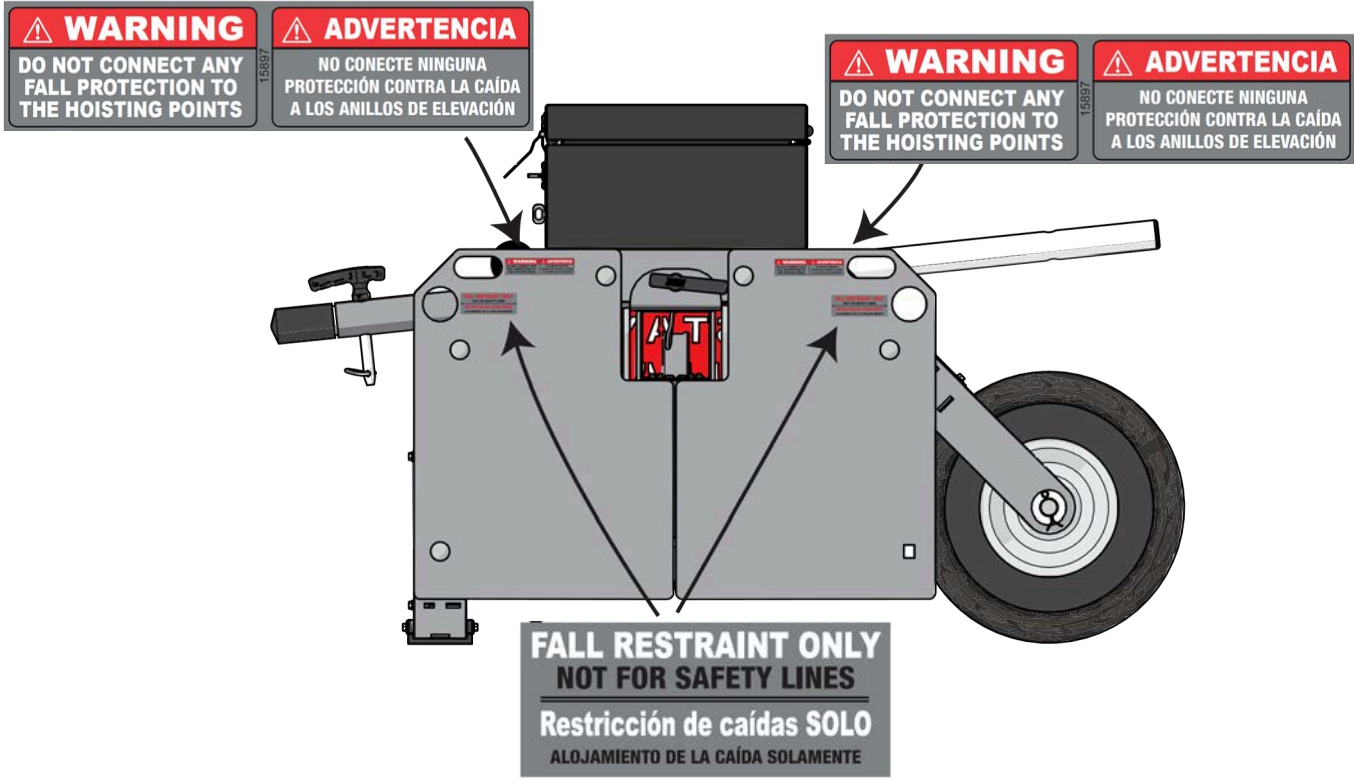

## DECLARATION OF CONFORMITY

Declaration Date: 08.11.2021  
Rev. 0

<b>DECLARATION NO.</b>	ETR-72810, 72841_R0
<b>PART NUMBER(S):</b>	72810, 72841
<b>PART DESCRIPTION:</b>	Penetrator X3 Cart (PX3)
<b>ADDITIONAL INFORMATION REGARDING THIS DOCUMENT OR STANDARD(S) EVALUATED:</b> .	

**TIE DOWN ENGINEERING** DECLARES THAT THE PRODUCT(S) LISTED ABOVE IS IN CONFORMITY WITH THE REQUIREMENTS OF THE FOLLOWING PERFORMANCE STANDARDS.

<b>STANDARD(S):</b> <ul style="list-style-type: none"><li>• OSHA 1926 Fall Protection Criteria OSHA</li><li>• 1910 Personal Fall Protection Systems</li></ul>
---

\*\*\* This certificate declares that the above standard(s) was met by the requirements of such standard(s). Testing was performed under normal operating measures. The results of testing apply only to the sample(s) tested and to the specific test(s) performed. This certificate is only issued for products which have passed the testing requirements of the standard(s) listed. The end-user is responsible for using the product(s) for its intended purpose(s) only and must review all manuals and instructional documentation prior to use. \*\*\*

Tie Down Engineering, Inc.  
605 Stonehill Drive, SW  
Atlanta, GA 30336

404-344-0000  
sales@tiedown.com  
www.tiedown.com



8/9/2021

Test Report		
<b>Test Operator(s):</b>	Wilson Ha, Lynea Rivera, Daniel Mathis	
<b>Test Date:</b>		
<b>Part Number(s):</b>	72810, 72841	
<b>Part Revision:</b>	0	
<b>Internal Test Report:</b>	ITR-72810, 72841_PO	
<b>Third Party (if applicable):</b>		
Test Summary		
Test Specification	Test Criteria	Test Result
OSHA 1910 Subpart I App D OSHA 1926 Subpart M App C	<ul style="list-style-type: none"> <li>6 ft. freefall drop test using a 310 lb. test mass</li> <li>Test performed with 6 ft. PEAs. Test mass must not hit the ground or floor.</li> </ul>	PASS
OSHA 1910.140(d)	<ul style="list-style-type: none"> <li>Personal fall arrest systems—</li> <li>1910.140(d)(i)</li> <li>System performance criteria. In addition to the general requirements in paragraph (c) of this section, the employer must ensure that personal fall arrest systems:                             <ul style="list-style-type: none"> <li>1910.140(d)(i)(i)</li> <li>Limit the maximum arresting force on the employee to 1,800 pounds (8 kN);</li> <li>1910.140(d)(i)(ii)</li> <li>Bring the employee to a complete stop and limit the maximum deceleration distance the employee travels to 3.5 feet (1.1 m);</li> <li>1910.140(d)(i)(iii)</li> <li>Have sufficient strength to withstand twice the potential fall energy of the employee falling from a distance of 6 feet (1.8 m), or the free fall distance permitted by the system;</li> </ul> </li> </ul>	PASS

Tie Down Engineering, Inc.  
605 Stonehill Drive, SW  
Atlanta, GA 30336

404-344-0000  
sales@tiedown.com  
www.tiedown.com

**OSHA 1910 & OSHA 1926**

The PX3 Cart (72810) successfully passed a 310 lb. drop test up to 3 consecutive drops. The Penetrator Device (72841) successfully deployed into the substrates. The test weights did not contact the ground or lower structure. See table below for the substrate layers tested.

Part Numbers	Test Material	Max Fall arrest
72810	TPO	3
	2" EPS/ISO Foam 1/2" Plywood	
72841	EPDM	3
	2" EPS/ISO Foam 1/2" Plywood	
72810	20ga Steel Roof Deck 1/2" Plywood	3
	22ga Steel Roof Deck 1/2" Plywood	
72841	1/2" Plywood	3

**Penetrator (PX3) (PN 72810)**

- Weight of Cart: 430 lbs.
- Max # of Workers in Fall Arrest: 3
- Minimum setup distance from the leading edge: 8 feet

Tie Down Engineering, Inc.  
605 Stonehill Drive, SW  
Atlanta, GA 30336

404-344-0000  
sales@tiedown.com  
www.tiedown.com

## Hoisting PX3

Locate the Hoisting Points on PX3 for crane hoisting the unit onto your work surface.

**DO NOT** hook to the fall arrest or fall restraint shackle safety line connectors when lifting the cart.

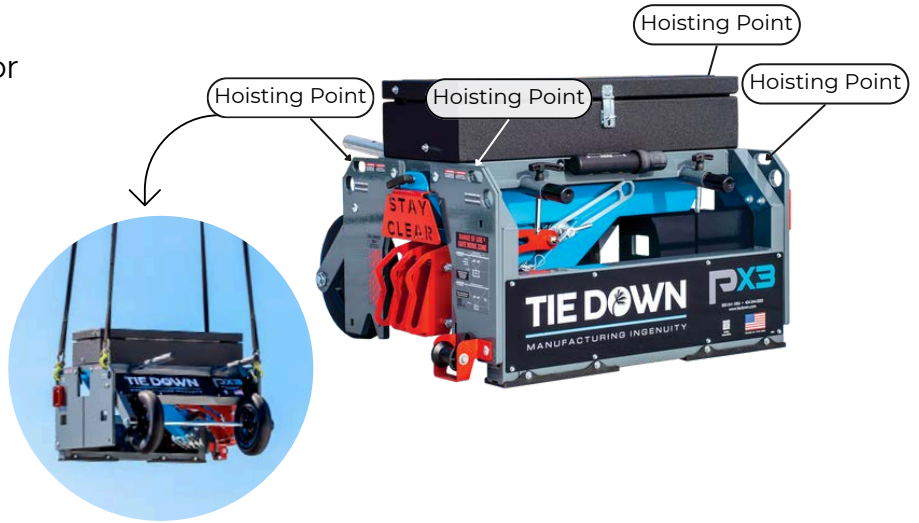

## Hoisting Safety Precautions

Loads may slip, if the PX3 is not hoisted properly, this could result in injury or death.

**DO NOT** use with damaged slings or chains.

Utilize appropriate rigging gear for overhead lifting.

Utilize rigging gear within the industry standards and the manufacturer's recommendations.

Conduct regular inspection and maintenance of the rigging gear.

**DO NOT** hook to the fall arrest or fall restraint shackle safety line connectors when lifting the cart.

## Jobsite Mobility

Once hoisted to the jobsite, the PX3 functions as a mobile anchorage device, designed for easy mobility.

To achieve optimal lifting and maneuverability, extract the retractable handles from their resting positions and re-pin to longest length, allowing workers to position the device with minimal strain.



# Roofing Load Requirements

**Before the PX3 cart is hoisted to any roofing deck the user MUST VERIFY THAT THE DECK CAN ACCOMMODATE THE LOAD REQUIREMENTS.**

Verify that the surface that the PX3 will be used on is capable of supporting both the device, weighing 430 lbs, and personnel using it. Inspect that the entire area to determine if the working surfaces have the strength to support users safely.

**CAPACITY:** PX3 mobile fall protection unit is engineered to accommodate up to three individuals for fall arrest and two for fall restraint with a collective weight (including clothing, tools, etc.) not exceeding 310 lbs. per person. The device is designed to support a maximum of five persons simultaneously while connected to the PX3 at any given time.

**IMPORTANT:** Do NOT initiate work requiring fall protection until both the PX3 system and its corresponding Fall Restraint System (FRS) and Personal Fall Arrest System (PFAS) are fully installed. Under no circumstances should any component of the FRS or PFAS, including the PX3 unit, be disabled or repositioned until work requiring fall protection has concluded.

## Rescue Winch (Purchased Separately)

**IMPORTANT: BEFORE USING THIS UNIT, A RESCUE PLAN MUST BE ADOPTED.**

**OSHA requires employers to provide a quick rescue of employees in the event of a fall or employers shall assure that employees are able to rescue themselves. Consult with your roofing distributor/supplier for fall rescue equipment.**

### Rescue Winch Accessory

Sold Separately, the PX3 Rescue Winch is designed to rescue a fallen worker, and is only meant to be used in case of emergency.

Stored safely in the storage tool box, the rescue winch is designed to be installed quickly and easily, in case of rescue.

### Rescue Winch Kit

Winch, brackets, roller and all hardware.

Part ID: 72819

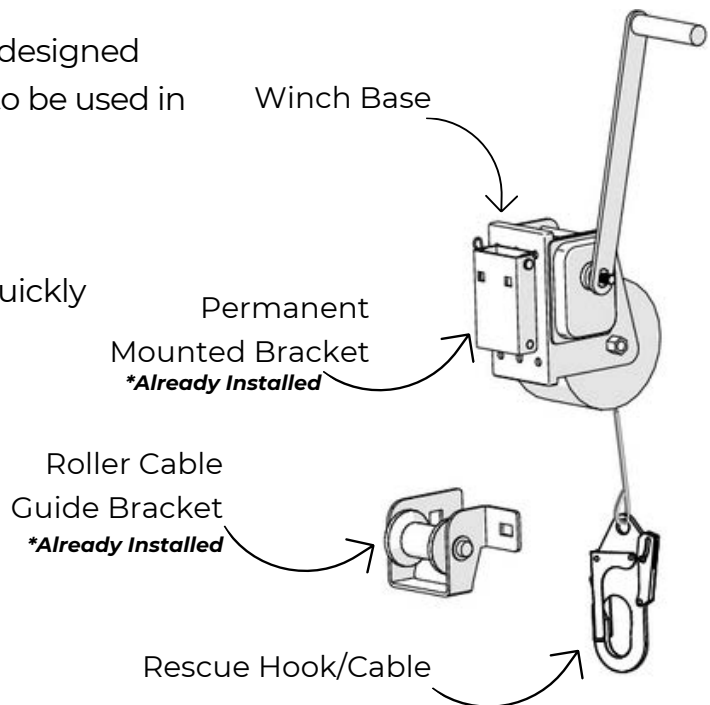

# Rescue Winch Installation

## Rescue Event

In the event of a rescue, remove the rescue winch from the tool storage box. Slide the winch base over and down on the permanent mounted bracket.

Make sure the lower slots fit over the mounting pin on the lower portion of the permanent bracket.

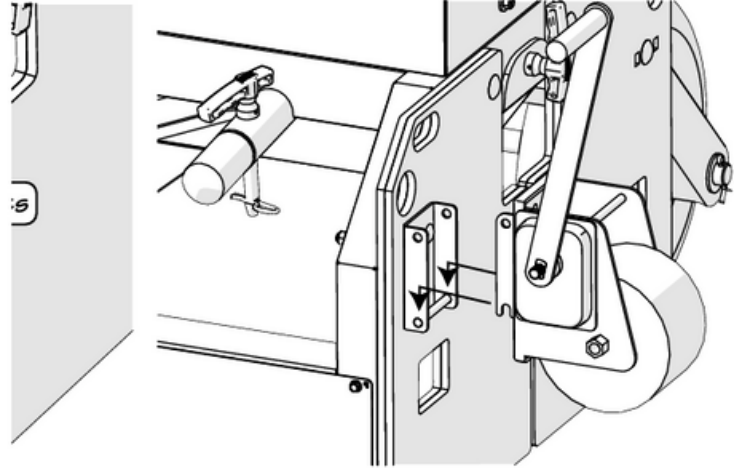

## Secure Winch Base

With one hand holding the winch in place, slide the mounting pin in through both winch bracket and the permanent bracket.

Slide the pin completely through the other side and secure with a safety pin as shown.

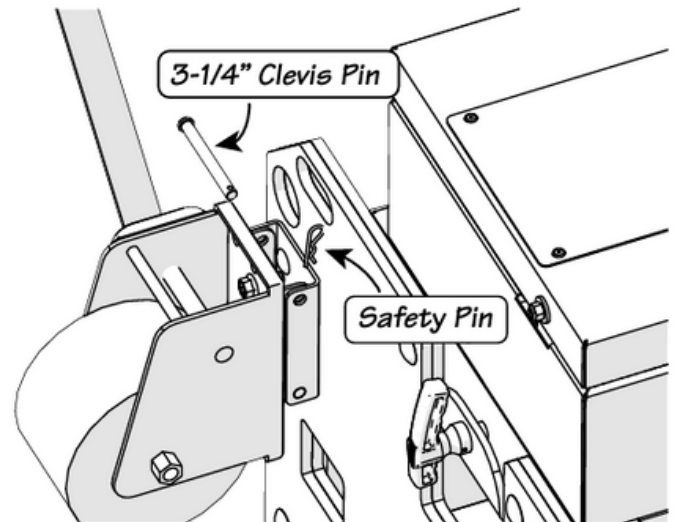

## Secure Cable

Release about 4 ft. of cable from the winch. Slide the rescue hook through the hole below the winch. Standing above the PX3, bend over and pass the rescue hook/cable through the roller cable guide bracket. The rescue hook should pass under the roller and about the bottom of the roller bracket.

**WARNING - Be careful not to come in contact with the five penetrating spikes.**

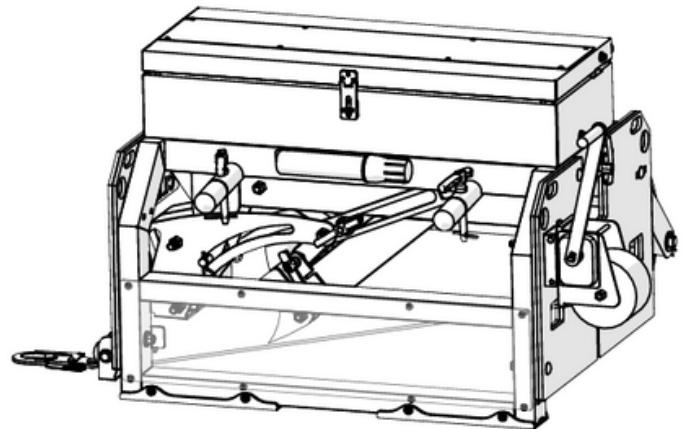

# Procedure for Handling the PX3 After a Fall

## Before rescuing a fallen employee....

***\*It is recommended to call 911 before making rescue attempt\****

Any rescuer must be tied off in a Fall Restraint System (FRS) before attempting to aid in a rescue. The number of rescuers allowed to tie off to the PX3 is 3 minus the number of fallen workers. Up to 2 (two) additional rescuers may tie off to the PX3 utilizing the two fall restraint tie-off shackles marked for FRS.

To use the Tie Down Rescue System for the PX3, you will need to also have a rescue pole accessible to properly reach the back dorsal D-ring of the worker who is being rescued.

**DO NOT ATTEMPT TO RESCUE THE WORKER UNLESS YOU ARE PROPERLY TIED OFF TO AN APPROPRIATE ANCHORAGE CONNECTION. ATTEMPTING TO RESCUE A WORKER WHEN NOT BEING PROPERLY CONNECTED TO AN APPROVE ANCHORAGE CONNECTION CAN RESULT IN SERIOUS INJURY INCLUDING DEATH.**

Workers must be properly trained in the use of the Tie Down Rescue System PRIOR to use. Do not use the Tie Down Rescue System unless you are trained by a competent person and that training must be documented to have been conducted prior to use. Failure to properly train on the safe use of the Tie Down Rescue System could result in serious injury including death.

## Evaluate the situation

The event that led to the fall may create additional risk that need to be addressed. Determine whether the fallen worker is to be lifted back to the roof top or lowered to the ground.

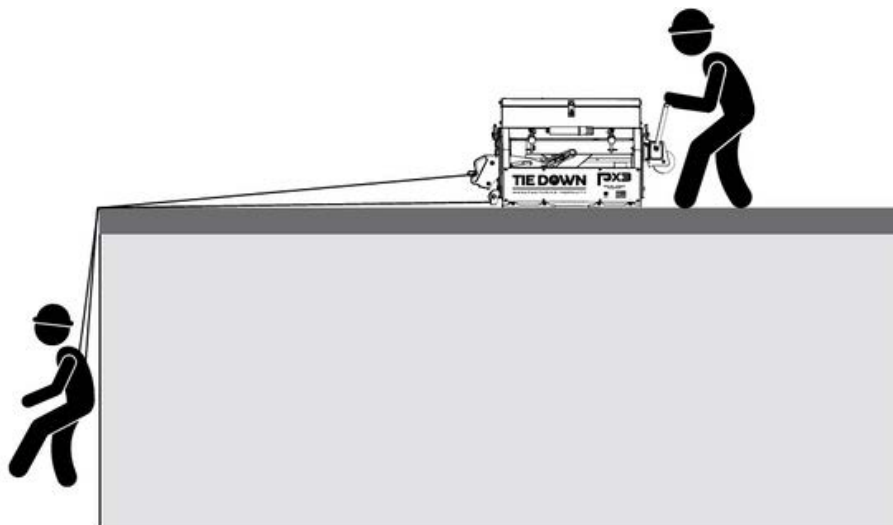

## If the Worker is Conscious

Release the cable from the winch and lower it to the fallen worker. Have the fallen worker hook the cable to his harness.

If the cable length and ground conditions allow, it is recommended to lower the worker safely to the ground. If the ground environment is not safe or the cable length is not long enough, then raise the fallen worker to the roof top.

# Procedure for Handling the PX3 After a Fall

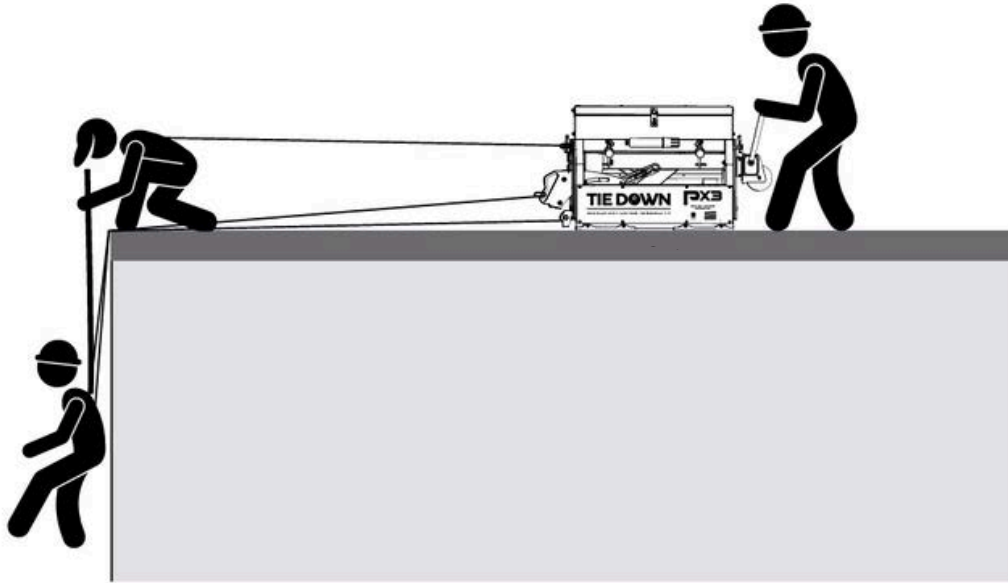

## **If the Worker is Unconscious**

If the fallen worker is unconscious or unable to hook themselves up to the rescue cable additional rescue help will be needed. The additional worker must be tied off to the PX3. Using a rescue pole attach the hook/ cable to the fallen worker.

If the cable length and ground conditions allow, it is recommended to lower the worker safely to the ground. If the ground environment is not safe or the cable length is not long enough, then raise the fallen worker to the roof top.

Treat the worker for suspension trauma and any other injuries.

Arrange for transportation to the nearest hospital.

# Procedure for Resetting the PX3 After a Fall

Prior to disengaging the PX3 after deployment as the result of a fall incident, make certain that the rescue procedure has been successfully completed.

The five penetrating spikes will be somewhat buried into the roof after activation.

Follow these steps to reset the PX3 Device:

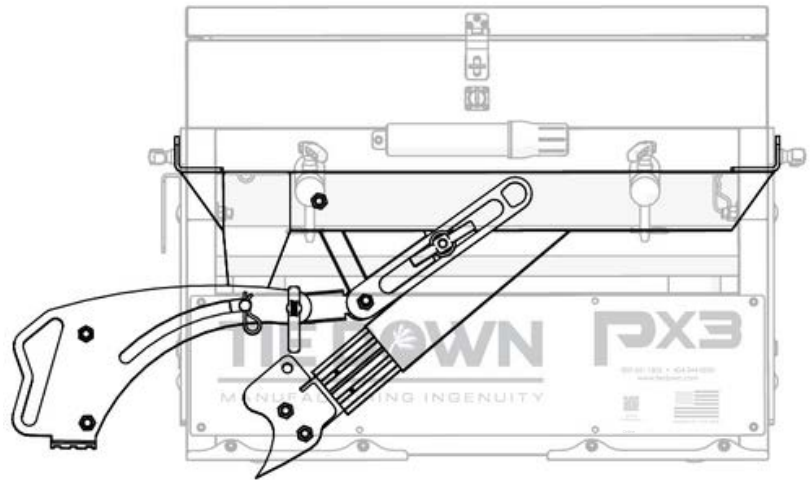

**PX3 Device shown in the engaged position**

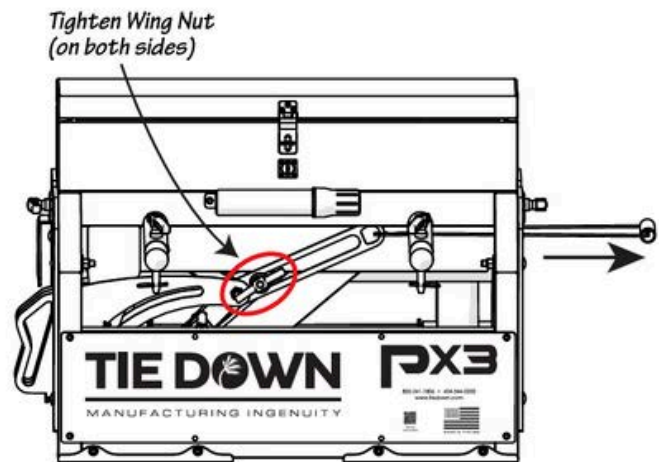
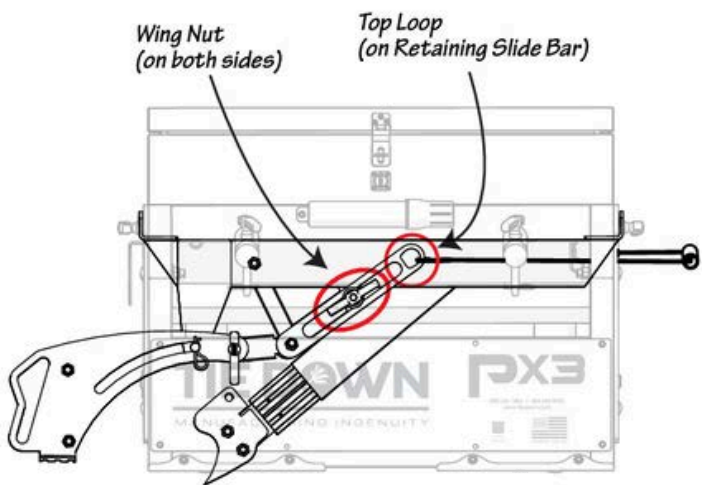

1. Loosen the large wing nuts on both sides of the PX3 device.
2. Attach the pull hooks to the top loop of the retaining slide bar. Repeat for opposite side.

3. With a firm pull, pull the handle outward away from the PX3 cart. The Spike assembly will slide back to its original position.
4. Re-tighten the large wing nuts on both sides.

**Do not reuse the Penetrator after incident until fully inspected and any damaged parts have been replaced and recertification and inspection has been performed. See inspection check list on back cover.**

# Applications: Surfaces

## Recommended Surfaces:

- Thermoplastic Polyolefin (TPO) Membranes
- Polyisocyanurate (ISO)
- Expanded Polystyrene (EPS)
- EPDM Roofing Membranes
- Ballasted EPDM Membrane
- Metal Deck (20 ga. and 22 ga. ONLY)
- Plywood

## DO NOT Use on the Following Surfaces:

- Metal Deck less than 22 ga. or over 20 ga. (Structural Deck)
- Loose laid material not part of a complete finished system.
- Ice
- Snow
- Tectum Deck
- Concrete

**\*\*\*SEE DECLARATION OF CONFORMITY (DOC)  
PAGES 8-9 FOR SURFACE TESTING DETAILS\*\*\***

## Placement/Positioning of the PX3 Cart

**Prior to Positioning the PX3:** Verify that the surface is capable of supporting the Penetrator X3, and all personnel using it.

**During Repositioning the PX3:** Active fall restraint is maintained by a maximum length of five feet less than the distance of the cart to the leading edge. The attachment tie-off anchor points must be pointed toward the leading edge and the cart is set to travel parallel to the unprotected edge or leading edge. Position the PX3 such that the front guard plate is **minimum of 8 feet from the leading edge**, and in line with the center of the area to be worked.

**Unprotected Edge  
or Leading Edge**

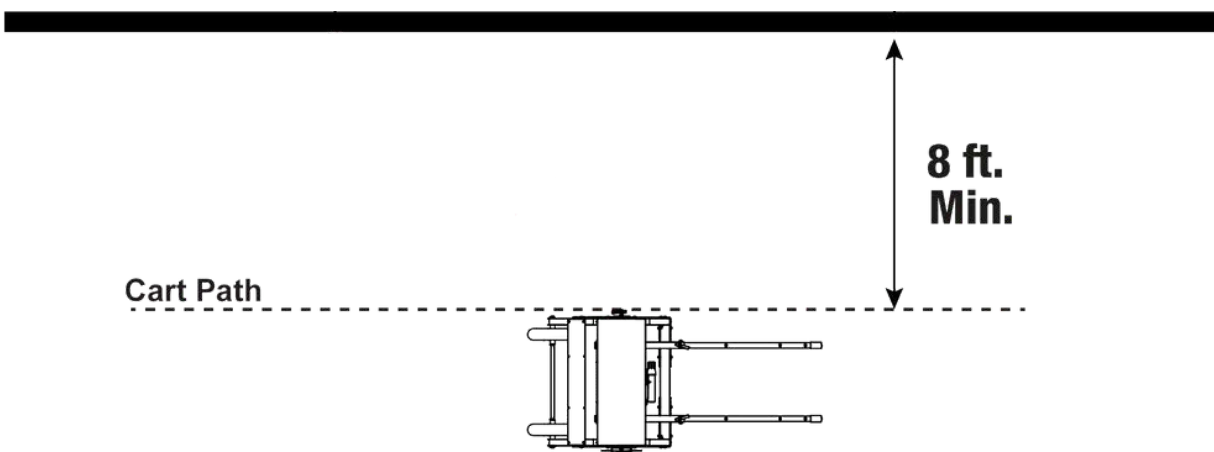

**IMPORTANT:** When repositioning the PX3, active fall restraint is maintained by a maximum length of five feet less than the distance of the cart to the leading edge. Once repositioned, place and re-pin retractable handles back in resting position.



# Range of Use

**Unprotected Edge or Leading Edge**

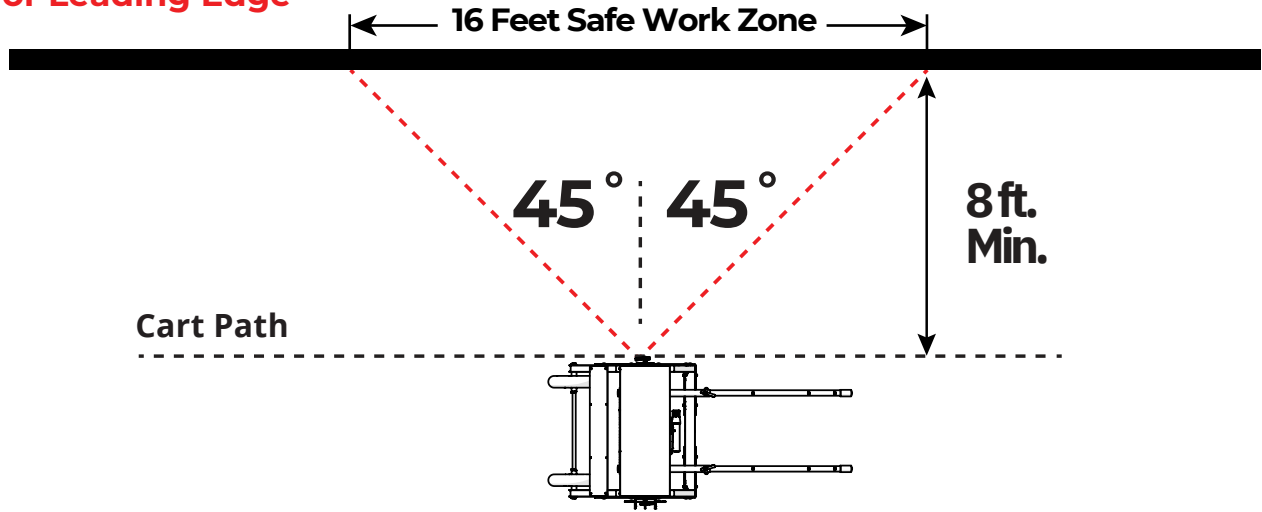

**Range of Use is double the distance from the leading edge up to 15 feet.**

**Unprotected Edge or Leading Edge**

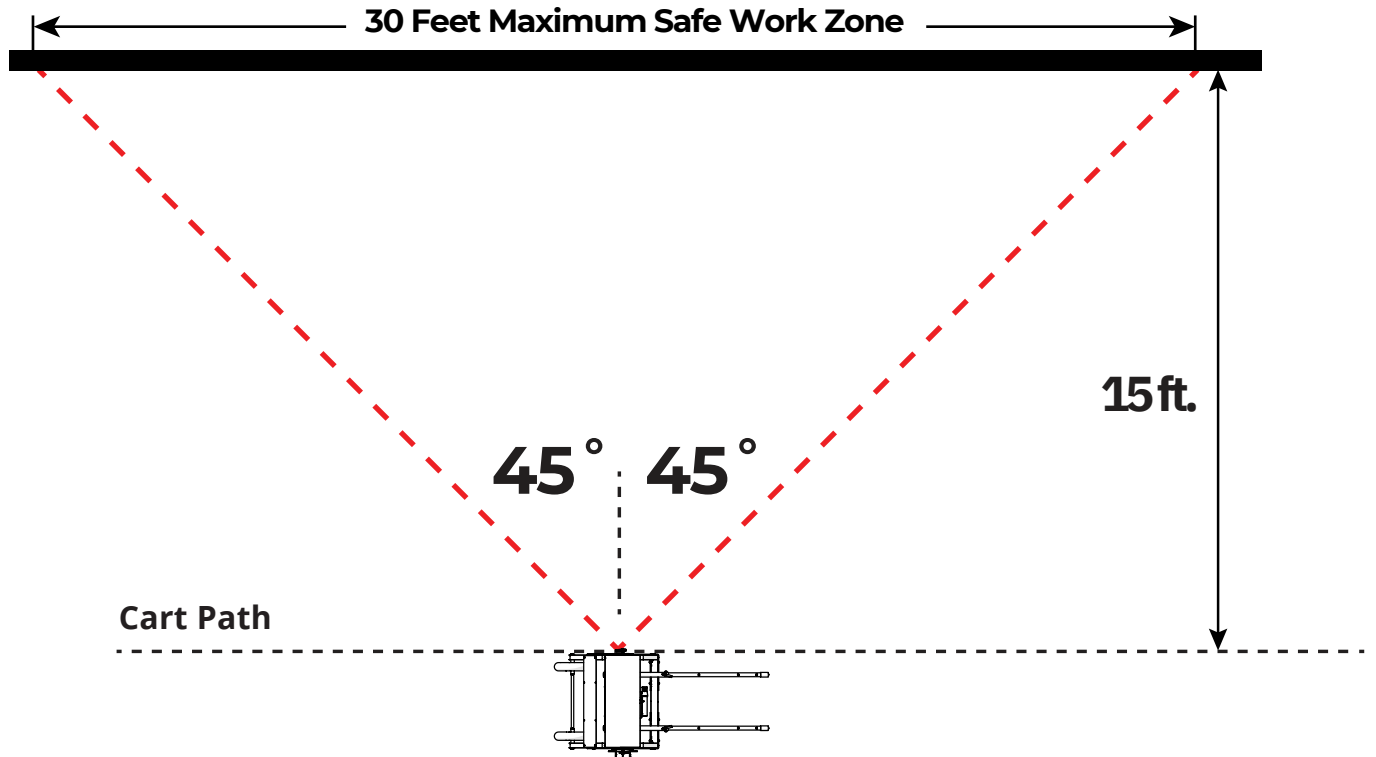

**After 15 feet the maximum Range of Use is 30 feet.**

# Connecting to the PX3

**DO NOT hook Personal Fall Arrest System (PFAS) to any point except a Fall Arrest or Fall Restraint Tie-off Anchor Point.**

When making connections, only use double-locking snap hooks and double-locking carabiners with this equipment. Only use connectors that are suitable to each application. Ensure all connections are compatible in size, shape and strength. Do not use equipment that is not compatible.

Ensure that all connectors are fully closed and locked.

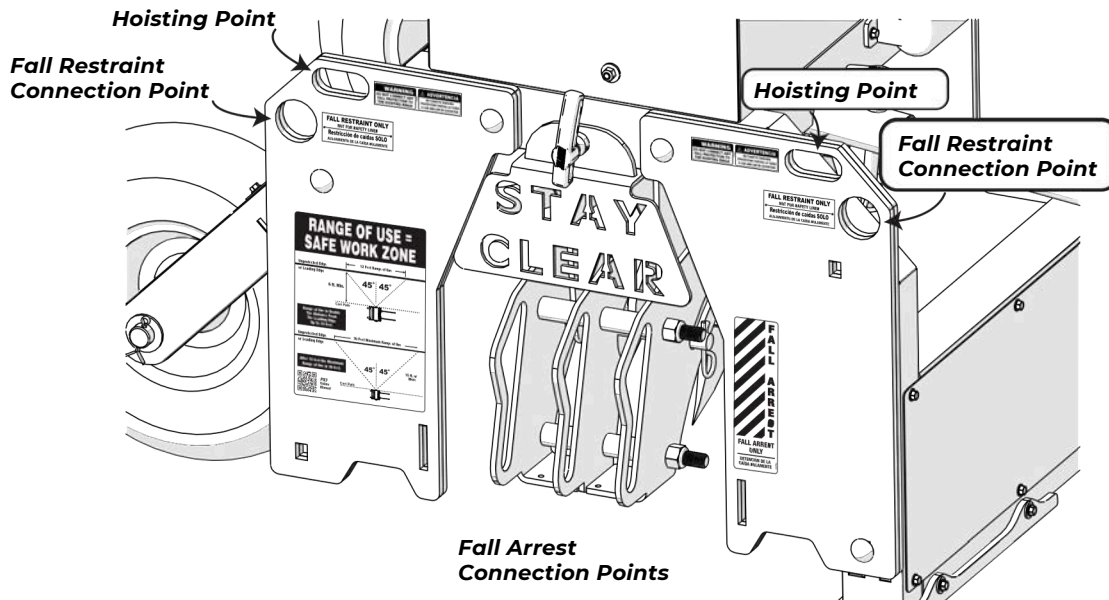

## The Fall Restraint Tie-Off

Two Fall Restraint Anchor tie offs are located on the top corners of the PX3 where labeled. The Fall Restraint tie offs DO NOT arrest falls. The user must ensure that the Fall Restraint worker is personally equipped with lanyards, harnesses, safety lines, etc., when working in conjunction with potential fall arrest workers.

**Do not attached fall restraints to the hoisting ring locations.**

**Do Not allow the fall restraint users to work close to any roof edge.**

## FALL ARREST TIE-OFF

The three Fall Arrest Tie Off points are located on the lower side of the PX3 in bright red, under of the stay clear guard. The user must ensure that the leading edge connectors and harness are properly attached.

**IMPORTANT: DO NOT allow workers to cross paths (cross lines) at anytime! Fall Restraint/Fall Arrest lines must never cross over each other. Crossed lines will cause the unit to not function as intended. Failure to maintain clear lines may cause a accident or death.**

**DO NOT OPERATE DAMAGED EQUIPMENT. DO NOT OPERATE EQUIPMENT THAT HAS BEEN MODIFIED. (Please use the Inspection and Maintenance Log contained within the instructions manual )**

# PX3

**MOBILE FALL PROTECTION**

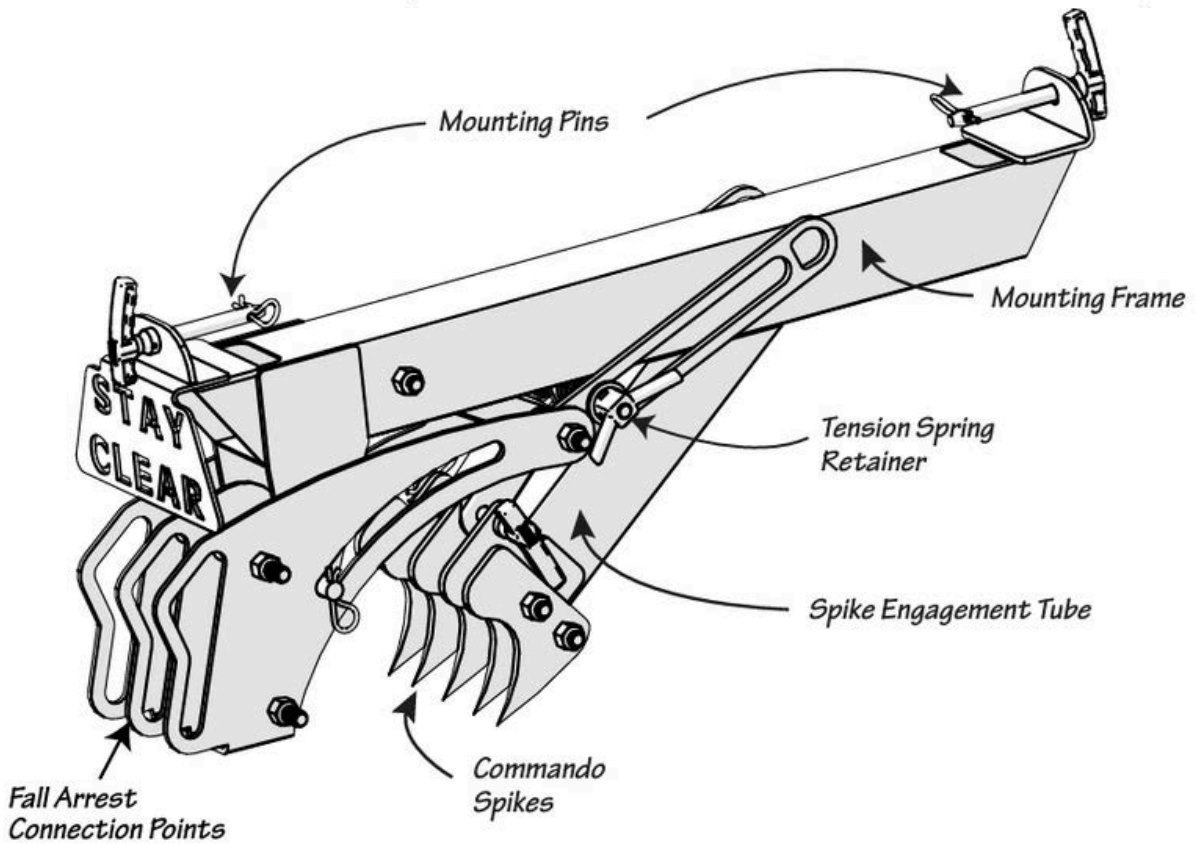
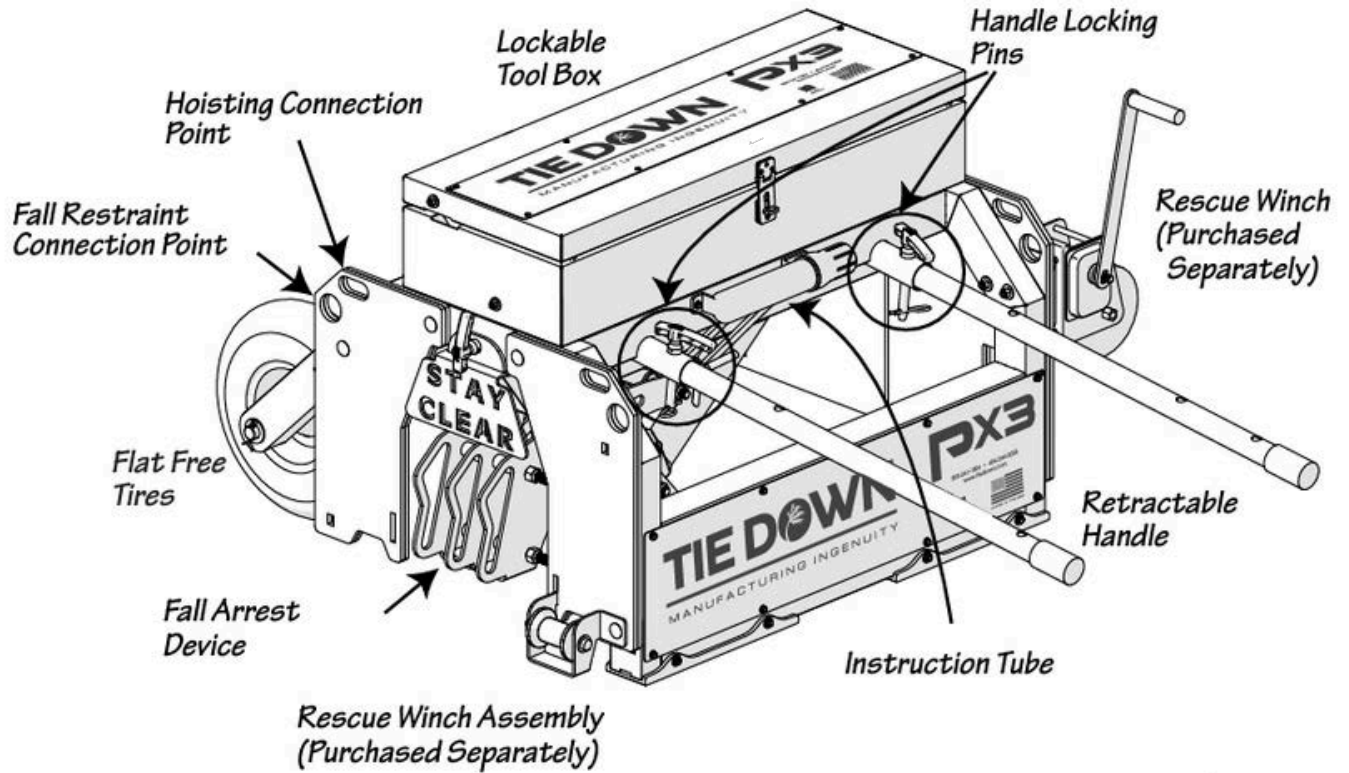



# Inspection Checklist and Maintenance Log



<b>PX3 Model #</b> _____	<b>Date of Purchase:</b> _____
<b>Serial Number:</b> _____	<b>Purchased From:</b> _____

<b>Roofing Cart</b>	<b>Date:</b>						
Frame: Free of Rust?							
Frame: Welded Connections?							
Axles/Wheels Rotate Properly?							
Overall Cart Parts?							

<b>Penetrator X3 Device</b>	<b>Date:</b>						
Frame: Free of Rust?							
Frame: Welded Connections?							
Mounting Pins (2)?							
Penetrator Spikes Free of Damage?							
Retaining Slide Bar Clear of Any Obstacles?							
Wing Nut Tightened/Retaining Slide Bar?							
Inner/Outer Spike Tube Engaged? (If "Yes" DO NOT USE)							
Pull Pins (5) Secured with Safety Cotter Pin?							
Safety and Warning Labels Readable?							

<b>Date</b>	<b>Corrective Action Taken:</b>